

FINE WALL / CEILING LAMP Config. 2

— TAF Studio

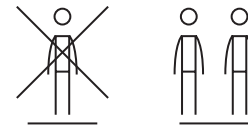

FINE WALL/CEILING, CONFIGURATION 2
INPUT: AC 230V, 50/60HZ
OUTPUT: 24V, 42W

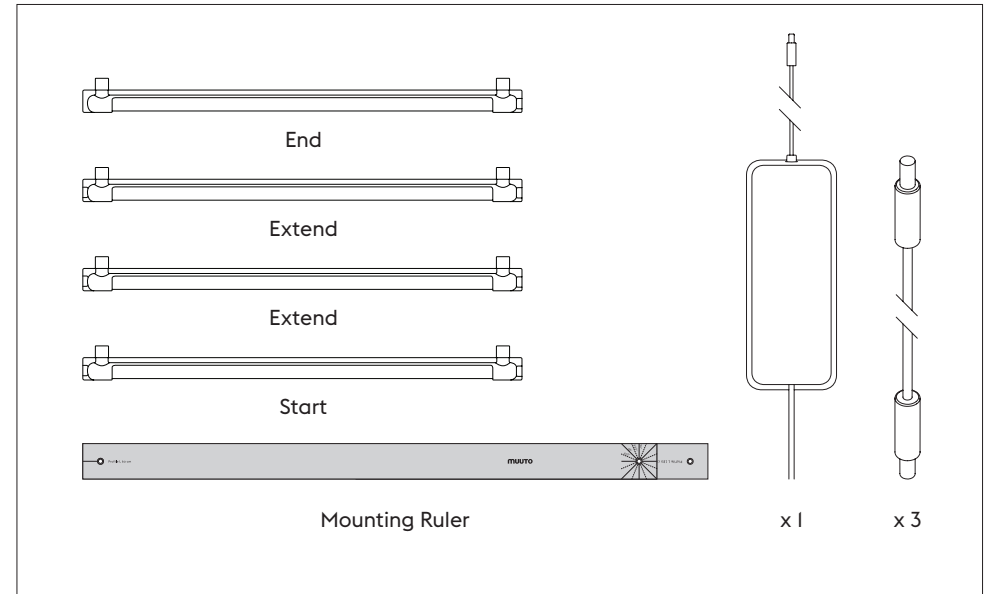

MOUNTING RULER

Profile Length:

Extend the mounting ruler for the correct lamp length:
60 cm / 90 cm / 120 cm

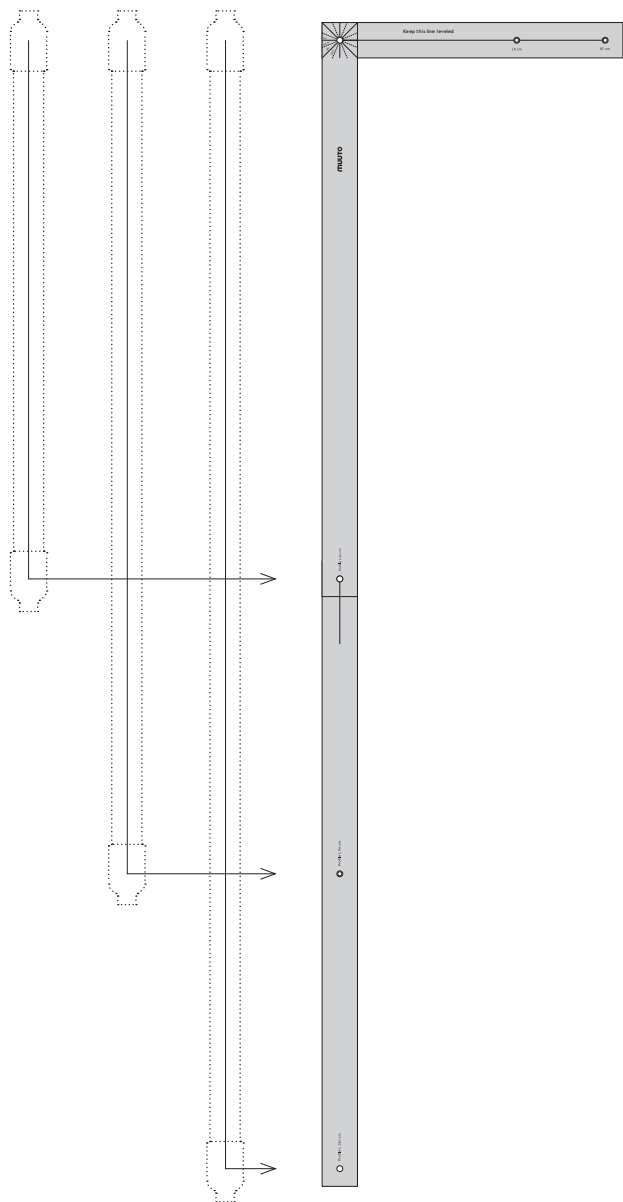

Angle:

Angle the mounting ruler to your preferred mounting angle: 90° / 67,5° / 45° / 22°

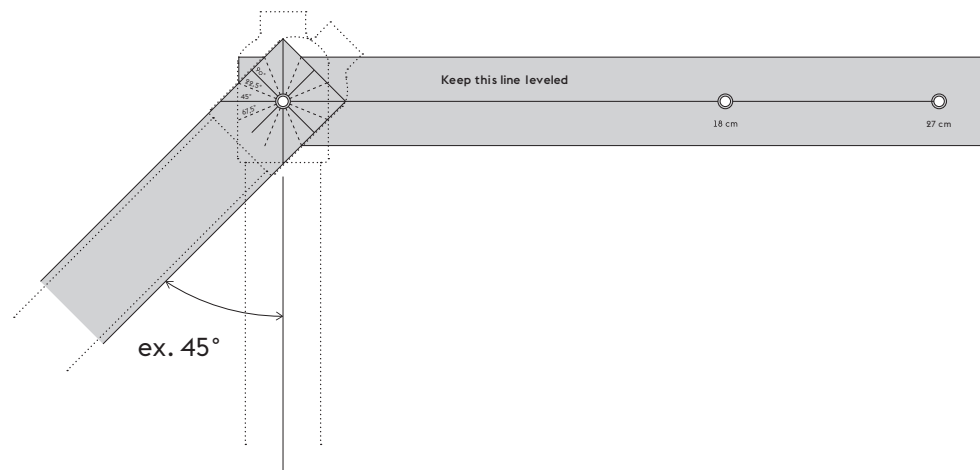

Distance:

Mark your desired distance between the lamps:
18 cm / 27 cm

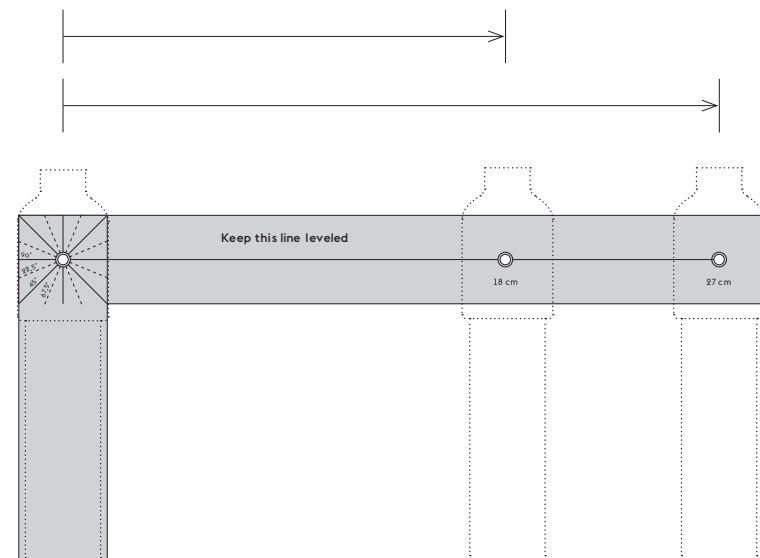

ASSEMBLY INSTRUCTION – SAMLEMANUAL – MONTAGEANLEITUNG
INSTRUCCIONES DE MONTAGE – INSTRUCCIONES DE MONTAJE

- 1 Place the driver on your chosen surface

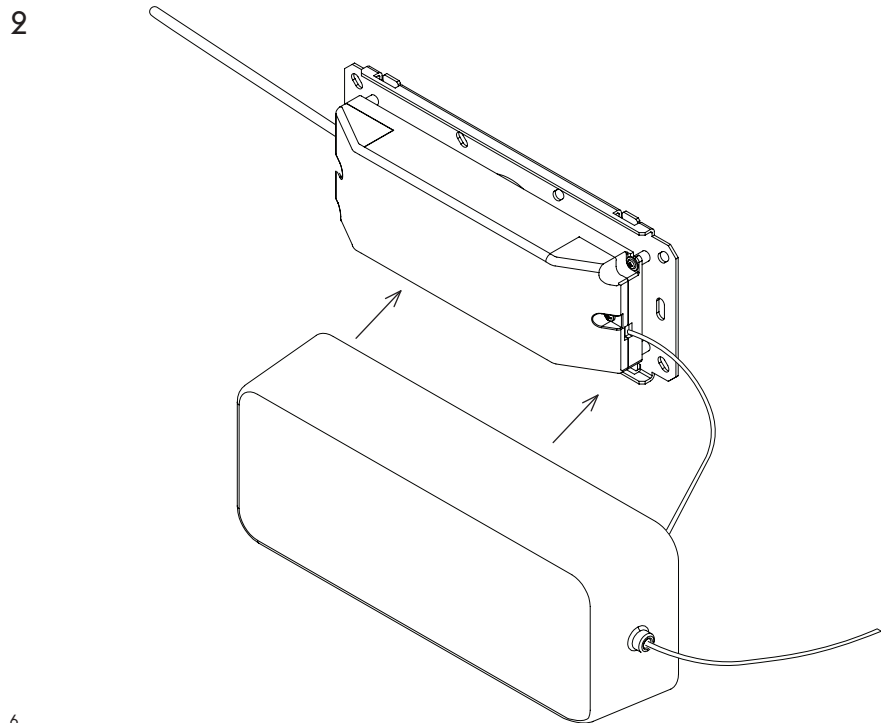
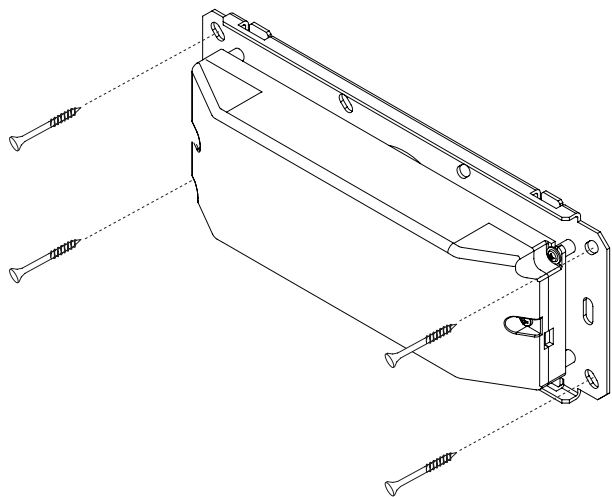

- 3 Begin with the 'start' profile, use the mounting ruler to mark the distance and angle, before tightening the screw

Refer to pages I2-I7 to see different lay-
outs within Configuration I

Layout example

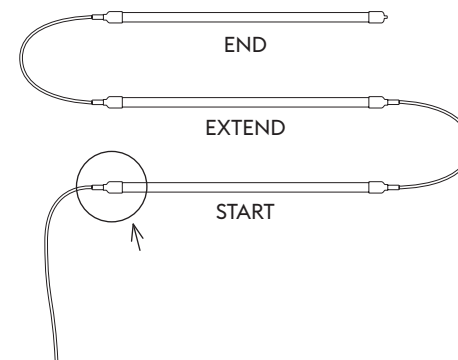

- 4 Remove the brackets from the profiles

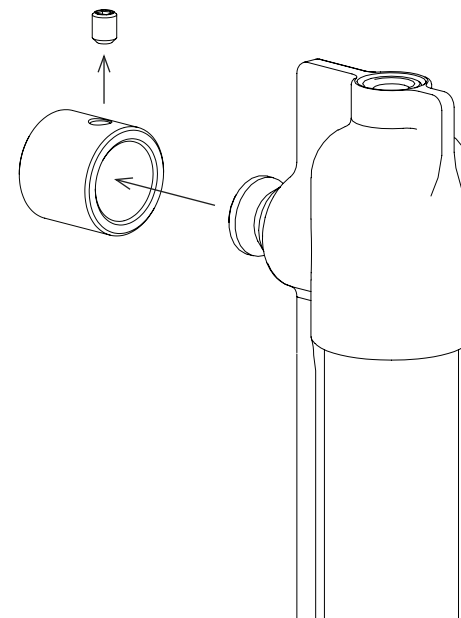

- 5 Please note that screws are not included with this product. You will need to purchase the appropriate screws separately for installation

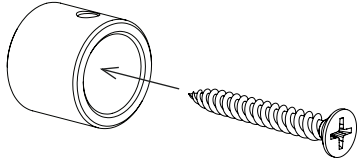

- 6 A. Place the brackets in the completed layout before mounting the profiles
B. Secure the profiles by tightening the screws using the hex key

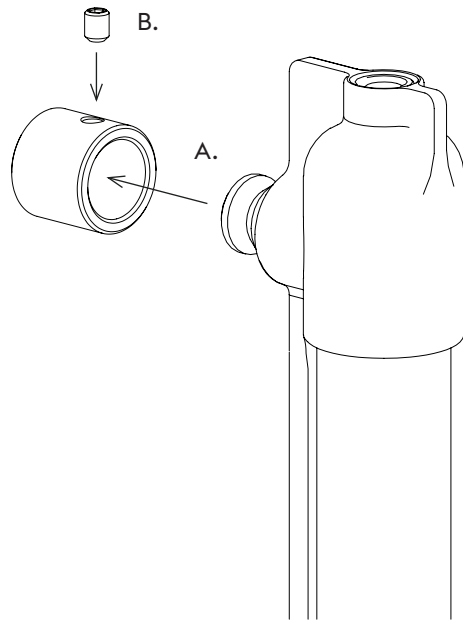

7

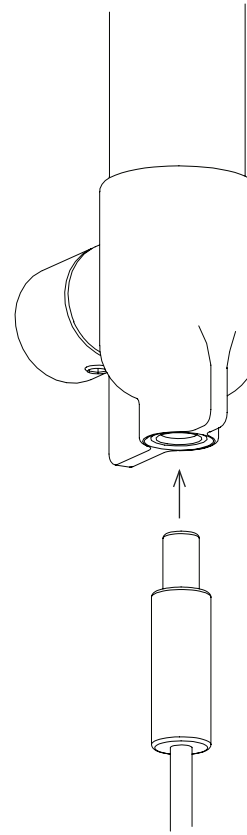

8

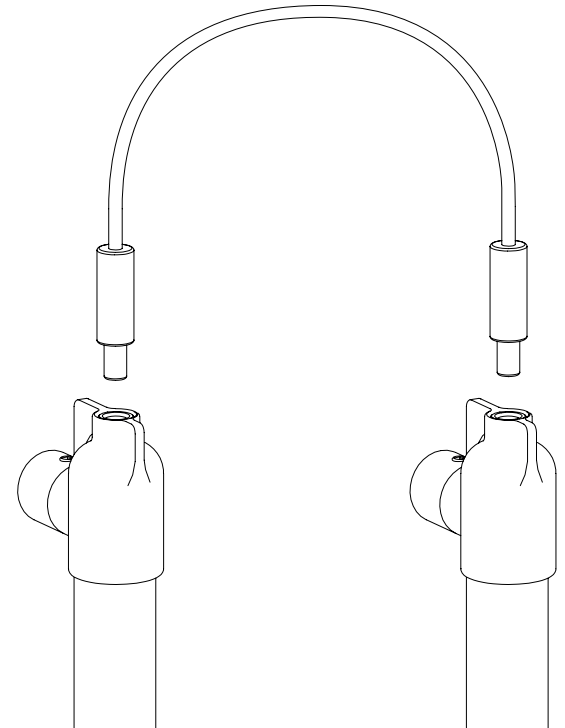

CONFIGURATION 2 – Layout A

A1)

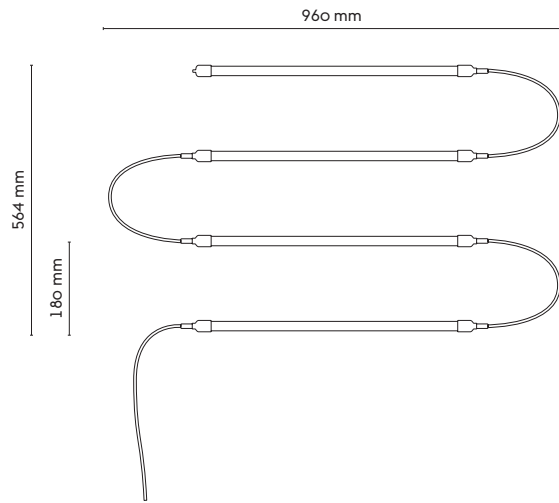

A3)

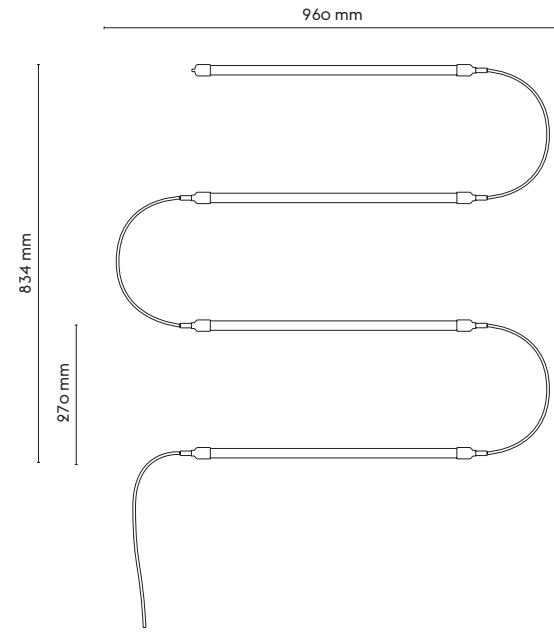

A2)

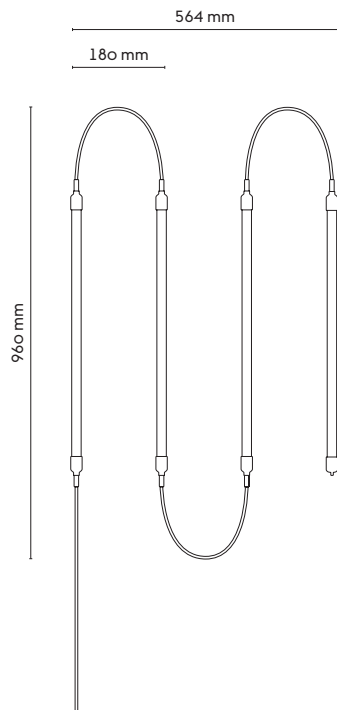

A4)

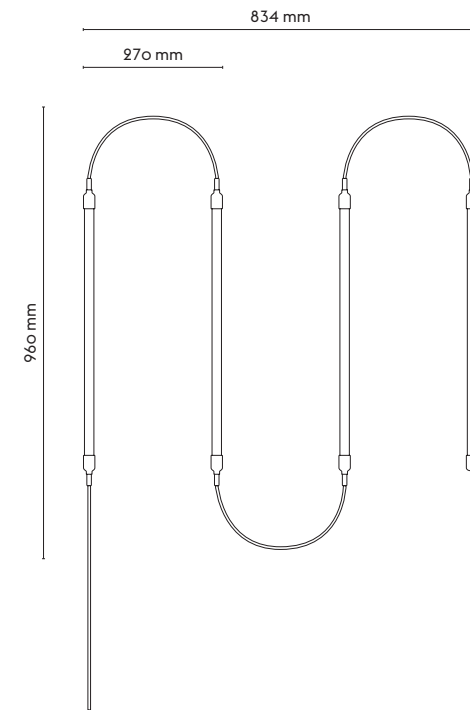

CONFIGURATION 2 – Layout B

B1)

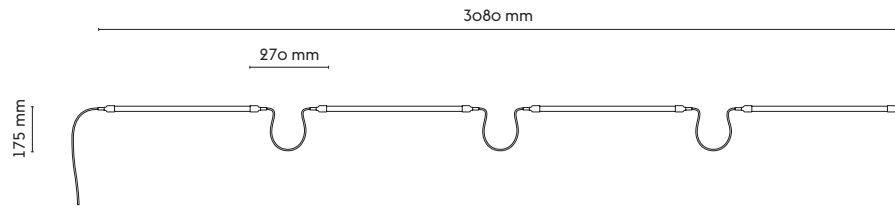

B2)

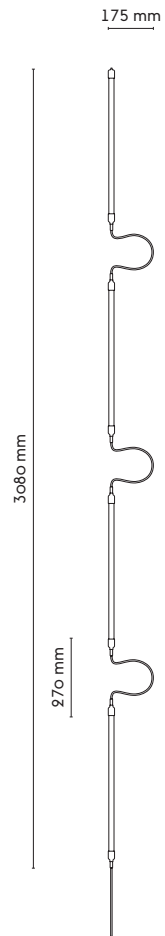

CONFIGURATION 2 – Layout C

C1)

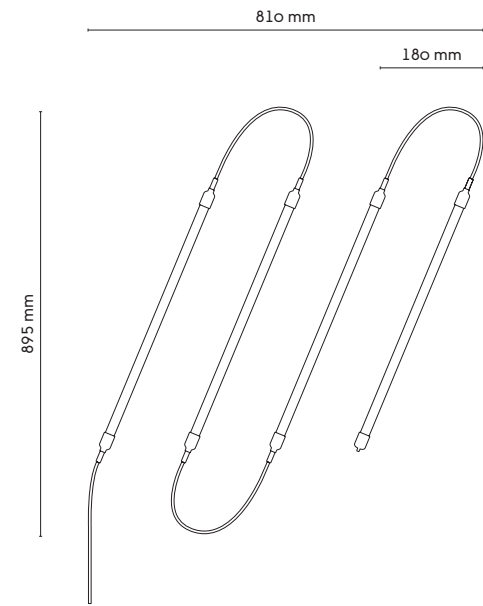

C2)

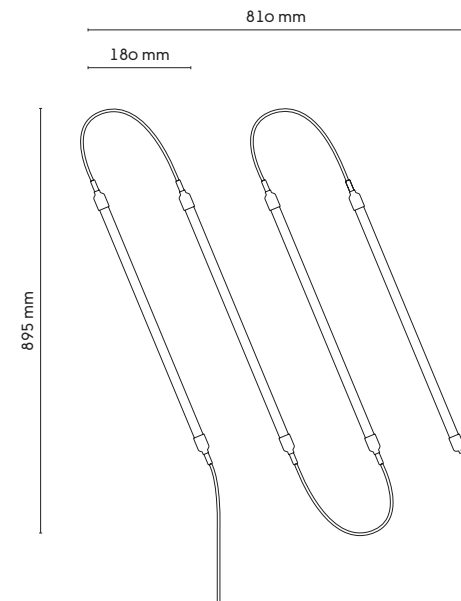

CONFIGURATION 2 – Layout D

D1)

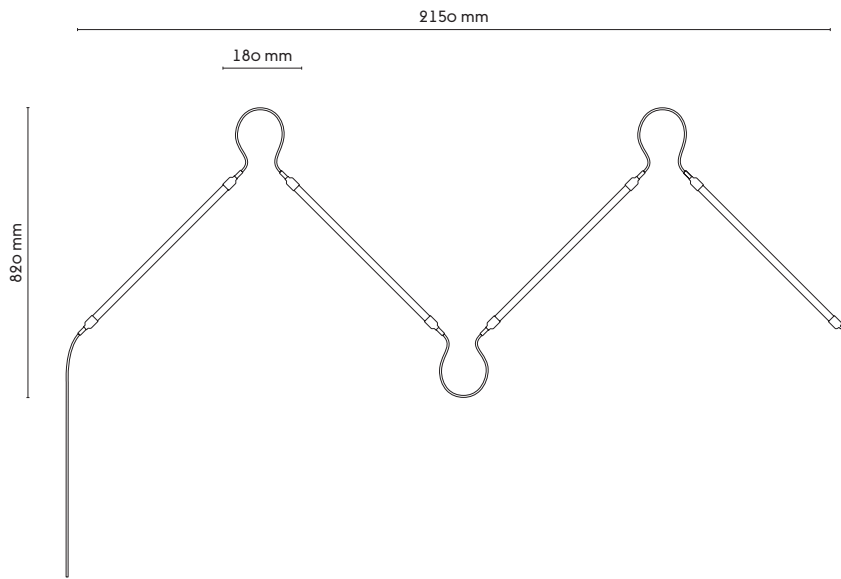

D2)

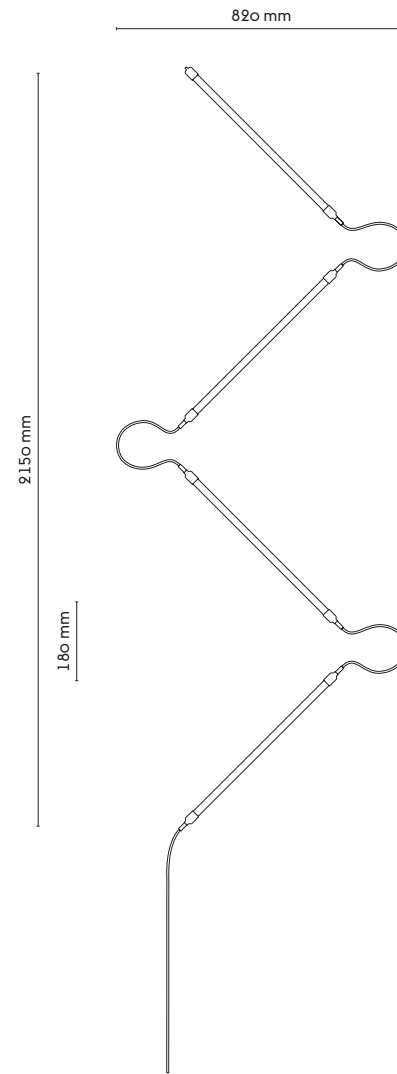

ATTENTION – BEMÆRK – ACHTUNG – ATTENTION – ATENCIÓN

- EN The light source contained in this luminaire must only be replaced by the manufacturer or a qualified electrician. If the external flexible cable or cord of this luminaire is damaged, it must only be replaced by the manufacturer or his service agent or a similar qualified person in order to avoid hazardous situations. Terminal block not included. Installation must be performed by a qualified person.
- DK Lyskilden i dette armatur må kun udskiftes af producenten eller en uddannet elektriker Hvis den eksterne fleksible ledning eller kablet til dette armatur beskadiges, skal det udskiftes af producenten, dennes servicerepræsentant eller en person med tilsvarende kvalifikationer for at undgå farlige situationer. Terminalblok medfølger ikke. Installation skal udføres af en kvalificeret person.
- DE Das in dieser Leuchte enthaltene Leuchtmittel sollte nur vom Hersteller oder von einem qualifizierten Elektriker ausgetauscht werden. Im Fall einer Beschädigung des externen flexiblen Leuchtenkabels darf der Austausch des Kabels aus Sicherheitsgründen ausschließlich durch den Hersteller oder eine vom Hersteller benannte Servicestelle oder eine Fachkraft mit geeigneter Qualifikation erfolgen. Der Klemmenblock ist nicht im Lieferumfang enthalten. Die Installation muss von einer qualifizierten Person durchgeführt werden.
- FR La source lumineuse de ce luminaire ne peut être remplacée que par le fabricant ou un électricien qualifié. Si le cordon ou le câble flexible externe de ce luminaire est endommagé, il doit être exclusivement remplacé par le fabricant, son représentant ou une personne qualifiée afin d'éviter tout danger. Boîtier de raccordement non inclus. L'installation doit être effectuée par une personne qualifiée.
- ES La sustitución de la fuente de luz que contiene esta luminaria debe ser llevada a cabo exclusivamente por el fabricante o un electricista profesional. Si el cable flexible externo de esta luminaria se dañara, debería ser reemplazado únicamente por el fabricante, o por su agente autorizado, o por una persona cualificada para así evitar peligros. Bloque de terminales no incluido. La instalación debe ser realizada por una persona cualificada.

CLEANING — RENGØRING — REINIGUNG — NETTOYAGE — LIMPIEZA

- EN Turn off electricity, clean with dry cloth.
- DK Afbryd elektricitet, rengør med tør klud.
- DE Strom abschalten, mit einem trocknenen tuch reinigen.
- FR Eteindre l'éctricité, nettoyer avec un chiffon humide.
- ES Apague la electricidad, limpie con un paño seco.